

VG - 8T RIPPLE MILL UNIT



Revolutionary design in nut cracking technology. Easy and low cost maintenance. No more re-building of ripple plate with welding.

FEATURES :

- Two sided stator rod to minimize maintenance downtime
- Cracking efficiency up to 98%
- Low Broken Kernel
- Low Noise Level
- Low Vibration

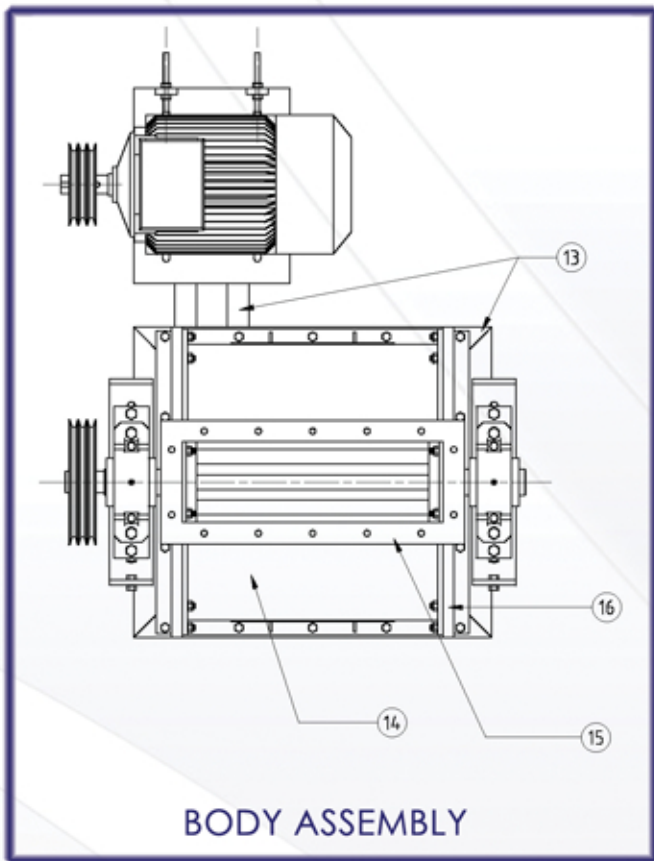

BODY ASSEMBLY

RIPPLE MILL BODY ASSEMBLY & ROTOR ASSEMBLY		
Item	Description	Qty
1	ROTOR SHAFT	1 Pc
2,4	ROTOR END PLATE	2 Pcs
3,5	M16x50 Countersink Bolt+Nut	16 Pcs
6	ROTOR ROD WEARING	48 Pcs
7	ROTOR ROD	48 Pcs
8,10	ROTOR RING PLATE	2 Pcs
9,11	M12x20 Countersink Bolt	8 Pcs
12	PLUMMER BLOCK HOUSING SNV-120L+22213 CCK	2 Pcs
13	BASE PLATE	1 Pc
14	HOUSING SHELL PLATE	2 Pcs
15	INLET FLANGE	1 Pcs
16	HOUSING END PLATE	2 Pcs

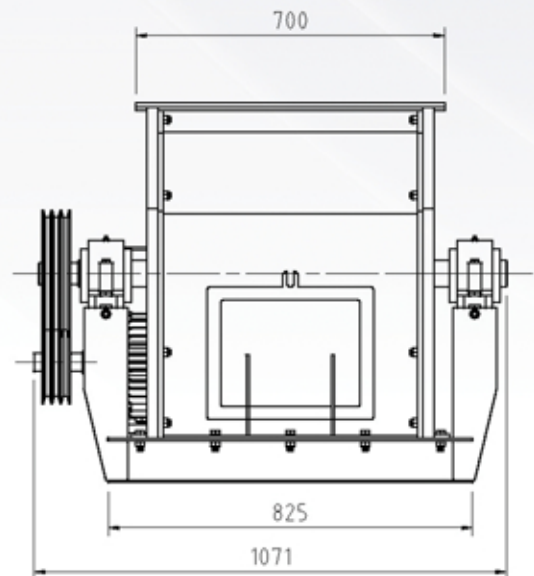
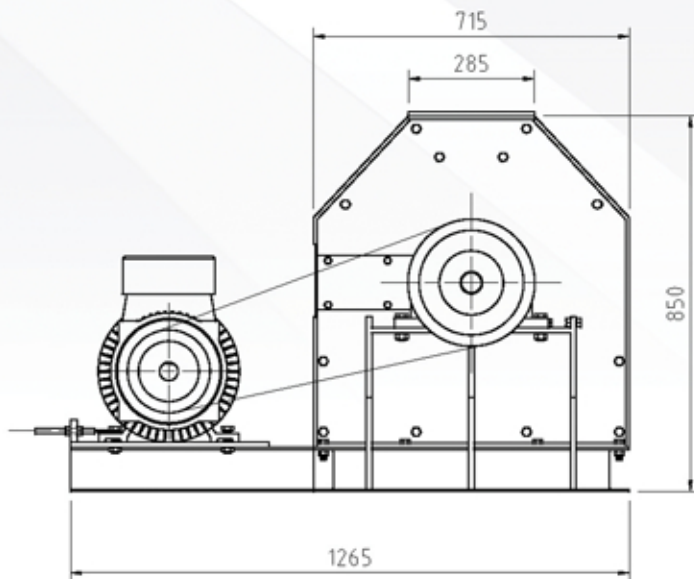
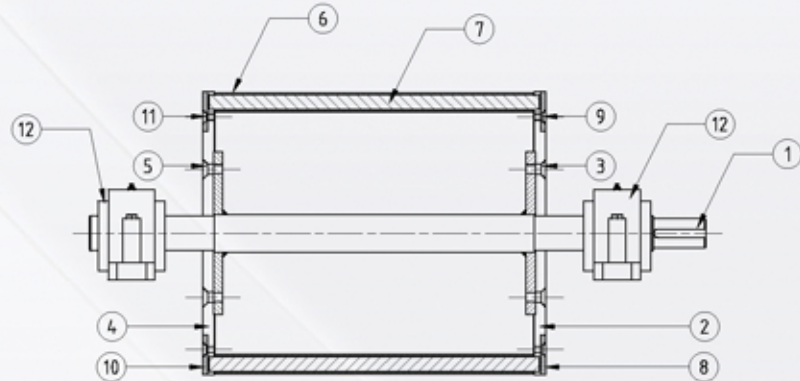

PT. Victorindo Kencana Teknik reserves the right to change all specifications and dimensions without prior notification.



PT. VICTORINDO KENCANA TEKNIK

Jl. Pulau Bunaken A3 - Kawasan Industri Medan III (KIM 3)

Medan 20242, North Sumatra - Indonesia

Tel : (+6261) 88809911 (Hunting), Fax : (+6261) 88809996

Email : sales.vkt@victorindogroup.com; sales@vkt.co.id

Website : www.vkt.co.id